

CENTRAL MACHINERY®

NITROGEN GENERATOR AND INFLATER

Model 95105

ASSEMBLY AND OPERATING INSTRUCTIONS



Due to continuing improvements,
actual product may differ slightly
from the product described herein.

Distributed Exclusively by



**HARBOR FREIGHT
TOOLS**



3491 MISSION OAKS BLVD., CAMARILLO, CA 93011
VISIT OUR WEB SITE AT [HTTP://WWW.HARBORFREIGHT.COM](http://www.harborfreight.com)

Copyright © 2006 by Harbor Freight Tools®. All rights reserved. No portion of this manual or any artwork contained herein may be reproduced in any shape or form without the express written consent of Harbor Freight Tools.

For technical questions and replacement parts, please call 1-800-444-3353

SPECIFICATIONS

Item	Description
Function	Inflates tires with nitrogen instead of air
Power Requirement	110 VAC, 60 Hz, 234 watts
Nitrogen Output	85 PSI from 3 internal tanks (50 liter total capacity)
Nitrogen Input	Rear connector for external tank
Air Inlet Pressure	130 to 140 PSI
Power Switch	Toggle: On/Off
Power Indicator	LED Lights when Power Switch is on.
Tire Inflator	Pressure gauge with tire chuck hose
Overall Dimensions	39-5/8 (H) x 13-3/4 (D) x 25-5/8 (W) inches; 4 inch floor clearance
Weight	174 lb.

SAVE THIS MANUAL

You will need the manual for the safety warnings and precautions, assembly instructions, operating and maintenance procedures, parts list and diagram. Keep your invoice with this manual. Write the invoice number on the inside of the front cover. Keep the manual and invoice in a safe and dry place for future reference.

GENERAL SAFETY RULES



WARNING!

READ AND UNDERSTAND ALL INSTRUCTIONS. Failure to follow all instructions listed below may result in electric shock, fire, and/or serious injury.

SAVE THESE INSTRUCTION

Work Area

1. **Keep your work area clean and well lit.** Cluttered benches and dark areas invite accidents.
2. **Do not operate power tools in explosive atmospheres, such as in the presence of flammable liquids, gases, or dust.** Power tools create sparks which may ignite the dust or fumes.
3. **Keep bystanders, children, and visitors away while operating a power tool.**

Distractions can cause you to lose control. Protect others in the work area from debris such as chips and sparks. Provide barriers or shields as needed.

Electrical Safety

4. **Avoid body contact with grounded surfaces such as pipes, radiators, ranges, and refrigerators.** There is an increased risk of electric shock if your body is grounded.
5. **Do not expose power tools to rain or wet conditions.** Water entering a power tool will increase the risk of electric shock.
6. **Grounded tools must be plugged into an outlet properly installed and grounded in accordance with all codes and ordinances. Never remove the grounding prong or modify the plug in any way. Do not use any adapter plugs. Check with a qualified electrician if you are in doubt as to whether the outlet is properly grounded.** If the tools should electrically malfunction or break down, grounding provides a low resistance path to carry electricity away from the user.
7. **Double insulated tools are equipped with a polarized plug (one blade is wider than the other). This plug will fit in a polarized outlet only one way. If the plug does not fit fully in the outlet, reverse the plug. If it still does not fit, contact a qualified electrician to install a polarized outlet. Do not change the plug in any way.** Double insulation eliminates the need for the three wire grounded power cord and grounded power supply system.
8. **Do not abuse the Power Cord. Never use the Power Cord to the Plug from an outlet. Keep the Power Cord away from heat, oil, sharp edges, or moving parts. Replace damaged Power Cords immediately.** Damaged Power Cords increase the risk of electric shock.
9. **When operating a power tool outside, use an outdoor extension cord marked “W-A” or “W”.** These extension cords are rated for outdoor use, and reduce the risk of electric shock.

Personal Safety

10. **Stay alert. Watch what you are doing, and use common sense when operating a power tool. Do not use a power tool while tired or under the influence of drugs, alcohol, or medication.** A moment of inattention while operating power tools may result in serious personal injury.
11. **Dress properly. Do not wear loose clothing or jewelry. Contain long hair. Keep your hair, clothing, and gloves away from moving parts.** Loose clothes, jewelry, or long hair can be caught in moving parts.
12. **Avoid accidental starting. Be sure the Power Switch is off before plugging in.** Plugging in power tools with the Power Switch on, invites accidents.
13. **Do not overreach. Keep proper footing and balance at all times.** Proper footing and balance enables better control of the power tool in unexpected situations.
14. **Use safety equipment. Always wear eye protection.** Dust mask, nonskid safety shoes, hard hat, or hearing protection must be used for appropriate conditions.

Tool Use and Care

15. **Do not force the tool. Use the correct tool for your application.** The correct tool will do the job better and safer at the rate for which it is designed.
16. **Do not use the power tool if the Power Switch does not turn it on or off.** Any tool that cannot be controlled with the Power Switch is dangerous and must be replaced.
17. **Disconnect the Power Cord Plug from the power source before making any adjustments, changing accessories, or storing the tool.** Such preventive safety measures reduce the risk of starting the tool accidentally.
18. **Store idle tools out of reach of children and other untrained persons.** Tools are dangerous in the hands of untrained users.
19. **Maintain tools with care. Keep cutting tools sharp and clean.** Properly maintained tools with a sharp cutting edge are less likely to bind and are easier to control. Do not use a damaged tool. Tag damaged tools “Do not use” until repaired.
20. **Check for misalignment or binding of moving parts, breakage of parts, and any other condition that may affect the tool’s operation. If damaged, have the tool serviced before using.** Many accidents are caused by poorly maintained tools.
21. **Use only accessories that are recommended by the manufacturer for your model.** Accessories that may be suitable for one tool may become hazardous when used on another tool.

Service

22. **Tool service must be performed only by qualified repair personnel.** Service or maintenance performed by unqualified personnel could result in a risk of injury.
23. **When servicing a tool, use only identical replacement parts. Follow instructions in the “*Inspection, Maintenance, And Cleaning*” section of this manual.** Use of unauthorized parts or failure to follow maintenance instructions may create a risk of electric shock or injury.

SPECIFIC SAFETY RULES FOR THIS PRODUCT

1. **Maintain labels and nameplates on the Nitrogen Generator and Inflator.** These carry important information. If unreadable or missing, contact Harbor Freight Tools for a replacement.
2. **Always wear ANSI-approved safety impact eye goggles and heavy work gloves when using the Nitrogen Generator and Inflator.** Using personal safety devices reduce the risk for injury. Safety impact eye goggles and heavy work gloves are available from Harbor Freight Tools.
3. **Maintain a safe working environment.** Keep the work area well lit. Make sure there is adequate surrounding workspace. Always keep the work area free of obstructions, grease, oil, trash, and other debris. Do not use a power tool in areas near flammable chemicals, dusts, and vapors. Do not use this product in a damp or wet location.

4. **Avoid unintentional starting.** Make sure you are prepared to begin work before turning on the **Nitrogen Generator and Inflater**.
5. **Do not force the Nitrogen Generator and Inflater.** This tool will do the work better and safer at the speed and capacity for which it was designed.
6. **Always unplug the Nitrogen Generator and Inflater from its electrical outlet before performing any inspection, maintenance, or cleaning procedures.**
7. **Never leave the Nitrogen Generator and Inflater unattended while running.** Turn power off if you have to leave the Nitrogen Generator and Inflater.
8. **Before each use, check all nuts, bolts, and hose connections for tightness.** Vibration during mixing may cause these to loosen.
9. **Keep extension cord off the ground and away from water.**
10. **Always connect the Line Cord to a Ground Fault Circuit Interrupter (GFCI) protected electrical outlet.**
11. **Install this product on a proper surface.** Locate on a flat, level, and solid surface that is capable of supporting the weight of the **Nitrogen Generator and Inflater**.

GROUNDING

 **WARNING!**

Improperly connecting the grounding wire can result in the risk of electric shock. Check with a qualified electrician if you are in doubt as to whether the outlet is properly grounded. Do not modify the power cord plug provided with the tool or product. Never remove the grounding prong from the plug. Do not use the tool if the power cord or plug is damaged. If damaged, have it repaired by a service facility before use. If the plug will not fit the outlet, have a proper outlet installed by a qualified electrician.

Grounded Tools with Three Prong Plugs

1. This product comes with a three prong plug. Tools marked with “Grounding Required” have a three wire cord and three prong grounding plug. The plug must be connected to a properly grounded outlet. If the tool should electrically malfunction or break down, grounding provides a low resistance path to carry electricity away from the user, reducing the risk of electric shock. (See Figure A.)
2. The grounding prong in the plug is connected through the green wire inside the cord to the grounding system in the tool. The green wire in the cord must be the only wire connected to the tool’s grounding system and must never be attached to an electrically “live” terminal. (See Figure A.)
3. Your tool must be plugged into an appropriate outlet, properly installed and grounded in accordance with all codes and ordinances. The plug and outlet should look like those in the following illustration. (See Figure A.)

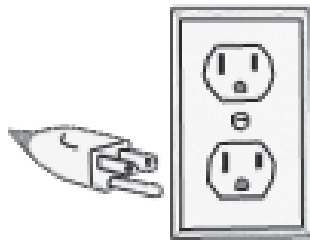

Figure A

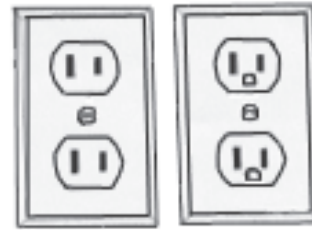

Figure B

Double Insulated Tools with Two Prong Plugs

4. A polarized plug (one blade is wider than the other) is used as a feature to reduce the risk of electric shock. This plug will fit in a polarized outlet only one way. If the plug does not fit fully in the outlet, reverse the plug. If it still does not fit, contact a qualified electrician. Never use with an extension cord unless plug can be fully inserted. Do not alter the plug.”
5. Tools marked “Double Insulated” do not require grounding. They have a special double insulation system which satisfies OSHA requirements and complies with the applicable standards of Underwriters Laboratories, Inc., the Canadian Standard Association, and the National Electrical Code. (See Figure B above.)
6. Double insulated tools may be used in either of the 120 volt outlets shown in the following illustration. (See Figure B above.)

EXTENSION CORDS

1. Grounded tools require a three wire extension cord. Double Insulated tools can use either a two or three wire extension cord.
2. As the distance from the supply outlet increases, you must use a heavier gauge extension cord. Using extension cords with inadequately sized wire causes a serious drop in voltage, resulting in loss of power and possible tool damage. (See Table A.)
3. The smaller the gauge number of the wire, the greater the capacity of the cord. For example, a 14 gauge cord can carry a higher current than a 16 gauge cord.
4. When using more than one extension cord to make up the total length, make sure each cord contains at least the minimum wire size required. (See Table A.)
5. If you are using one extension cord for more than one tool, add the nameplate amperes and use the sum to determine the required minimum cord size.
6. If you are using an extension cord outdoors, make sure it is marked with the suffix “W-A” (“W” in Canada) to indicate it is acceptable for outdoor use.
7. Make sure your extension cord is properly wired and in good electrical condition. Always replace a damaged extension cord or have it repaired by a qualified electrician before using it.
8. Protect your extension cords from sharp objects, excessive heat, and damp or wet areas.



Table A

RECOMMENDED MINIMUM WIRE GAUGE FOR EXTENSION CORDS* (120 VOLT)					
NAMEPLATE AMPERES (At Full Load)	EXTENSION CORD LENGTH				
	25 Feet	50 Feet	75 Feet	100 Feet	150 Feet
0 – 2.0	18	18	18	18	16
2.1 – 3.4	18	18	18	16	14
3.5 – 5.0	18	18	16	14	12
5.1 – 7.0	18	16	14	12	12
7.1 – 12.0	16	14	12	10	-
12.1 – 16.0	14	12	10	-	-
16.1 – 20.0	12	10	-	-	-

* Based on limiting the line voltage drop to five volts at 150% of the rated amperes.

SYMBOLOLOGY

Table B

	Double Insulated
	Canadian Standards Association
	Underwriters Laboratories, Inc.
V ~	Volts Alternating Current
A	Amperes
n_o <u>xxxx</u> /min.	No Load Revolutions per Minute (RPM)

UNPACKING

When unpacking, check to make sure that all the parts are included. Refer to the Assembly section, and the Assembly Drawing and Parts List at the end of this manual. Also see Figure C on the next page.

If any parts are missing or broken, please call Harbor Freight Tools at the number on the cover of this manual as soon as possible.

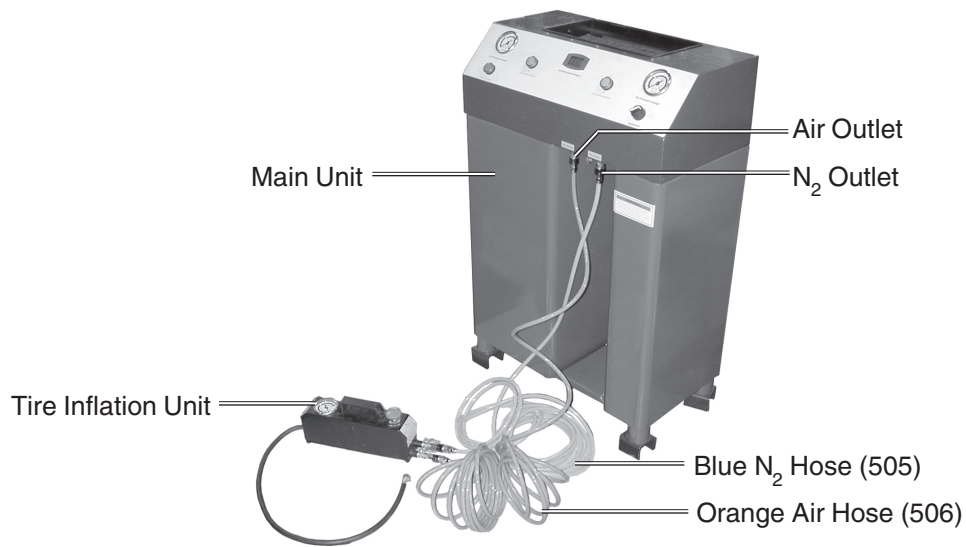

Figure C

ASSEMBLY INSTRUCTIONS

1. Connect the orange Air Hose (506) to the Air Inlet (when facing fittings, viewed on left side) of the Tire Inflation Unit, and to the Main Unit Air outlet. For these steps, refer to Figures C and D.

Refer to connector labels on each unit. Hose connectors snap on.

2. Connect the blue N₂ Hose (505) to the Tire Inflation Unit N₂ Inlet (right side when facing fittings), and to the Main Unit N₂ Outlet.
3. Connect the air supply hose (not supplied) from the air compressor (not supplied) to the Filter - Regulator (10) on the Main Unit. See Figure D, left-side.
4. Optionally, if an additional, larger N₂ supply tank is required, it can be connected to the rear of Main Unit labeled N₂ Outlet. The hose for this connection is not supplied.

Filter-Regulator (10)

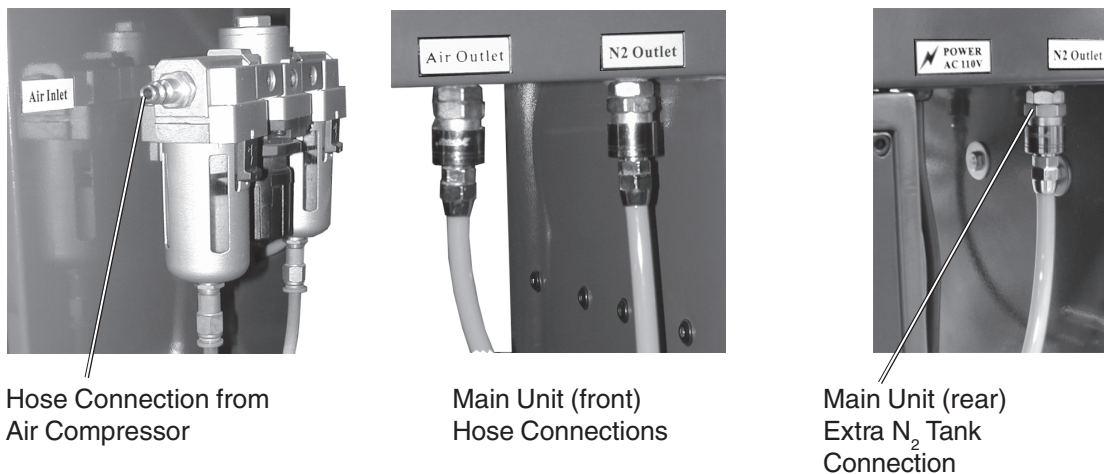

Hose Connection from
Air Compressor

Main Unit (front)
Hose Connections

Main Unit (rear)
Extra N₂ Tank
Connection

Figure D

OPERATING INSTRUCTIONS

Controls and Indicators

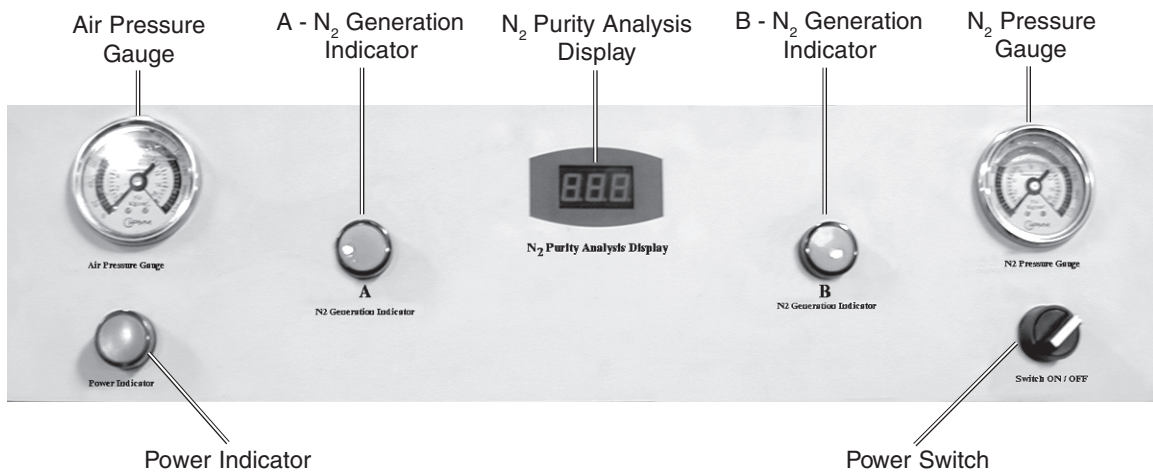

Figure E

Inflating Tires

This process extracts air from the tire and replaces it with Nitrogen. Follow these steps after the Assembly Instructions have been completed.

1. From the Tire Inflation Unit, connect the rubber hose (with tire valve clamp) to the tire air valve. The tire can be off or on the vehicle during this process. (If tire is left on the vehicle, jack it up to avoid possible sidewall damage to tire.)
2. Turn on the air compressor and set its regulator for between 130 and 140 PSI.
3. Turn the Power Switch to the On position.
 - The Power Indicator will light.
 - Check the Air Pressure Gauge for proper level.
4. From the Tire Inflation Unit, turn the Converse Valve clockwise, and open (inline with hose) the Air Inlet valve.

This step extracts the air from the tire. Inspect the tire for any leakage. Note: If this “flats” the tire, it should be raised so rim does not damage tire.

5. When air has been extracted, close (90° to air hose) the Air Inlet valve.

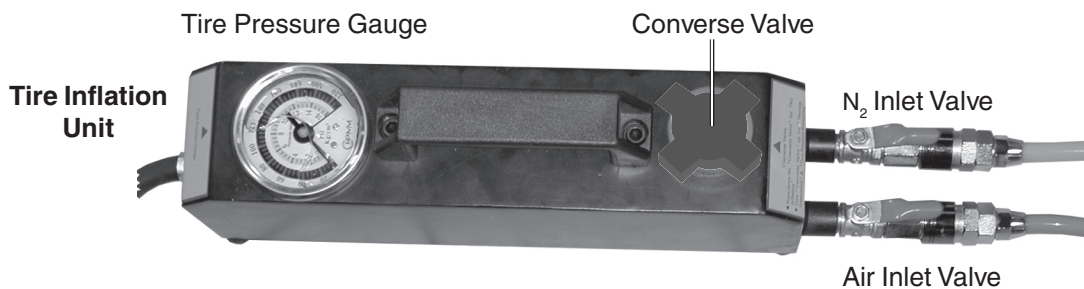

Figure F

6. From the Tire Inflation Unit, turn the Converse Valve counterclockwise, and open (inline with hose) the N₂ Inlet valve.
 - This step inflates the tire with Nitrogen.
 - Check the Tire Pressure Gauge on the Tire Inflation Unit, and inflate to the tire manufacturer's recommended tire pressure.
 - The A or B N₂ Generation Indicator will light. The N₂ Pressure Gauge should read 85 PSI.
 - Check the N₂ Purity Analysis Display on the Main Unit. Purity should read between 95% to 99%. If it does not, N₂ supply tank may be low.
7. When the tire is inflated to the proper pressure, close (90° to hose) the N₂ Inlet valve, and remove the rubber hose with tire valve clamp from the tire valve.
8. Turn the Nitrogen Generator and Inflater Power Switch to the Off position.
9. Turn the air compressor off and disconnect the air hose from the Nitrogen Generator and Inflater.

TROUBLESHOOTING

Problem	Probable Cause	Possible Solution
Tire does not inflate or deflate. - Power Switch on - Power Indicator on	<ol style="list-style-type: none"> 1. Air or N₂ hoses not correctly connected. 2. Air Compressor not supplying air pressure, or not connected. 3. Not following proper operation procedure. 4. Tire valve hose connector not inserted properly. 	<ol style="list-style-type: none"> 1. Review Assembly steps on page 8. 2. Check air compressor is on and hoses are correctly connected. 3. Review operating procedure on page 9. 4. Reconnect tire valve hose connector.
N ₂ Purity Analysis Display reads less than 95%	<ol style="list-style-type: none"> 1. Adjustment of the N₂ Purity Flow Rate screw is required 	<ol style="list-style-type: none"> 1. Adjust the N₂ Purity Flow Rate screw.

INSPECTION, MAINTENANCE, AND CLEANING

⚠ WARNING! Make sure the Power Switch of the NITROGEN GENERATOR AND INFLATER is in its “OFF” position and that the tool is unplugged from its electrical outlet before performing any inspection, maintenance, or cleaning procedures.

1. **Before each use**, inspect the general condition of the Nitrogen Generator and Inflator. Check for loose screws, misalignment or binding of moving parts, cracked or broken parts, damaged electrical wiring, and any other condition that may affect its safe operation. If abnormal noise or vibration occurs, have the problem corrected before further use. **Do not use damaged equipment.**
2. Periodically recheck all hoses, valves, nuts, bolts, and screws for tightness.
3. After each daily use of this unit, drain the moisture and impurities from the Filter-Regulator (10). This extends the life of the filter. To do this, remove the air supply hose from the Nitrogen Generator and Inflator, then press the Drain Button on the Filter-Regulator (10).
4. Before long-term unit storage, release pressure from the Nitrogen Generator and Inflator.
5. Replace the filter in Filter-Regulator (10) after one year of usage.
6. Store in a clean and dry location.
7. All maintenance and repairs must be completed by a qualified technician.

PLEASE READ THE FOLLOWING CAREFULLY

THE MANUFACTURER AND/OR DISTRIBUTOR HAS PROVIDED THE PARTS DIAGRAM IN THIS MANUAL AS A REFERENCE TOOL ONLY. NEITHER THE MANUFACTURER NOR DISTRIBUTOR MAKES ANY REPRESENTATION OR WARRANTY OF ANY KIND TO THE BUYER THAT HE OR SHE IS QUALIFIED TO MAKE ANY REPAIRS TO THE PRODUCT OR THAT HE OR SHE IS QUALIFIED TO REPLACE ANY PARTS OF THE PRODUCT. IN FACT, THE MANUFACTURER AND/OR DISTRIBUTOR EXPRESSLY STATES THAT ALL REPAIRS AND PARTS REPLACEMENTS SHOULD BE UNDERTAKEN BY CERTIFIED AND LICENSED TECHNICIANS AND NOT BY THE BUYER. THE BUYER ASSUMES ALL RISK AND LIABILITY ARISING OUT OF HIS OR HER REPAIRS TO THE ORIGINAL PRODUCT OR REPLACEMENT PARTS THERETO, OR ARISING OUT OF HIS OR HER INSTALLATION OF REPLACEMENT PARTS THERETO.

PARTS LIST

NOTE: Some parts are listed and shown for illustration purposes only and are not available individually as replacement parts.

Part #	Description	Qty.	Part #	Description	Qty.
1	Tool Plate	1	A3		
2	Screw, M6x10	10	301/302	Filtration Tank	2
3	Main Body	1	303	3-way Connector, 1/4"	1
4	Screw, M6x15	8	304	One-way Valve	2
5	Pressure Gauge	2	305	Elbow Connector, 1/4"	2
6	Power Indicator	1	306	Connector, 1/2" x 2	2
7	N ₂ Indicator	2	307	Connector, 1/2"	2
8	N ₂ Purity Analysis Board	1	308	Connector, 1/4" x 8	1
9	Power Switch	1	309	Elbow Connector, 1/4" x 8	1
10	Filter with Pressure Regulator	1	A4		
11	Elbow Connector, 1/4" x 8	1	401	Air Inlet Connector, 1/4"	3
12	3-way Connector	3	402	Ball Valve, 1/4"	2
13	Needle Valve	1	403	Pressure Gauge	1
14	Drain Hose, Blue	2	404	Connector, 1/4"	2
A1			405	Gauge Stand	3
101	Time Relay	1	406	Connector, 1/4" x 8	3
102	Pressure Switch (10 kgs)	1	407	Elbow Connector, 1/4" x 8	2
103	Pressure Switch (6 kgs)	1	408	Converse Valve	1
104	Electromagnetic Valve	1	409	Handle	1
105	Electromagnetic Valve (2-5)	1	410	Screw, M6 x 16	12
106	Quick Connector, 1/4"	3	411	Body, Tire Inflation Unit	1
107	Connector, 1/4" x 8	3	412	Support Screw	4
108	Electric Hose Sleeve	1	413	Vacuum Generator, Complete	1
109	Elbow Connector, 1/4" x 8	3	Other Parts		
110	Silencer	2	501	Power Cord	1
111	Screw, M4 x 30	2	502	Hose Sleeve	2
112	Connector, 10 x 1.25-8	2	503	Washer, M6	26
113	Screw, M4 x 15	4	504	Washer, M8	5
114	Screw, M4 x 20	2	505	N ₂ Hose, Blue	10M
115	Screw, M4 x 10	8	506	Air Hose, Orange	10M
116	Screw, M4 x 10, Flathead	2	507	Inflation Rubber Hose	1M
117	Transformer, 2W	1	508	Nut, M8	5
118	Transformer, 50W	1	509	Nut, M4	6
A2					
201	N ₂ Tank	1			
202	3-way Connector, 1/4"	1			
203	Connector, 1/4" x 3/8"	1			
204	Screw, M8 x 20	5			
205	Safety Valve	1			
206	Elbow Connector, 1/4" x 8	2			

MAIN UNIT MAJOR ASSEMBLY DRAWING

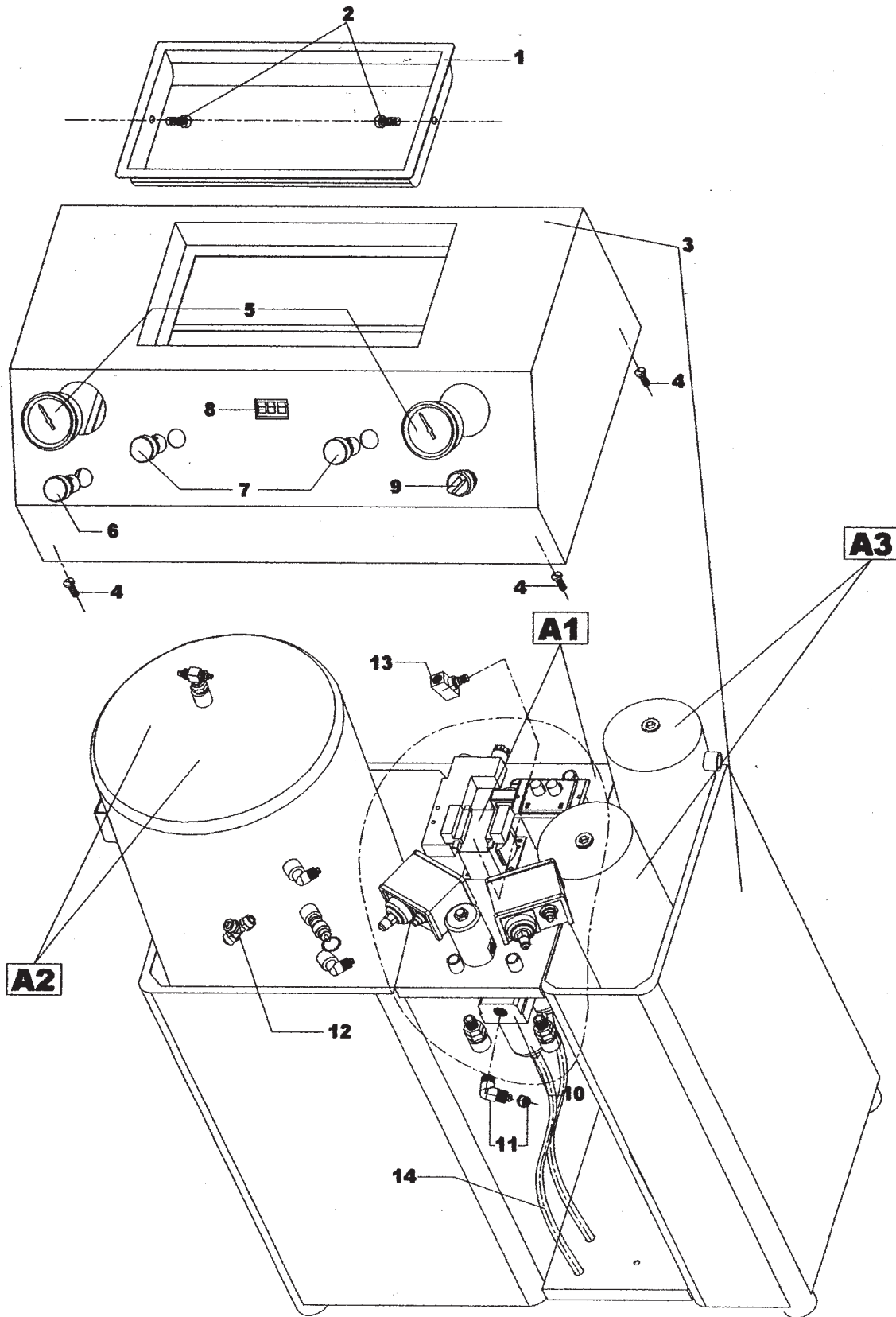

MAIN UNIT SUBASSEMBLY DRAWINGS

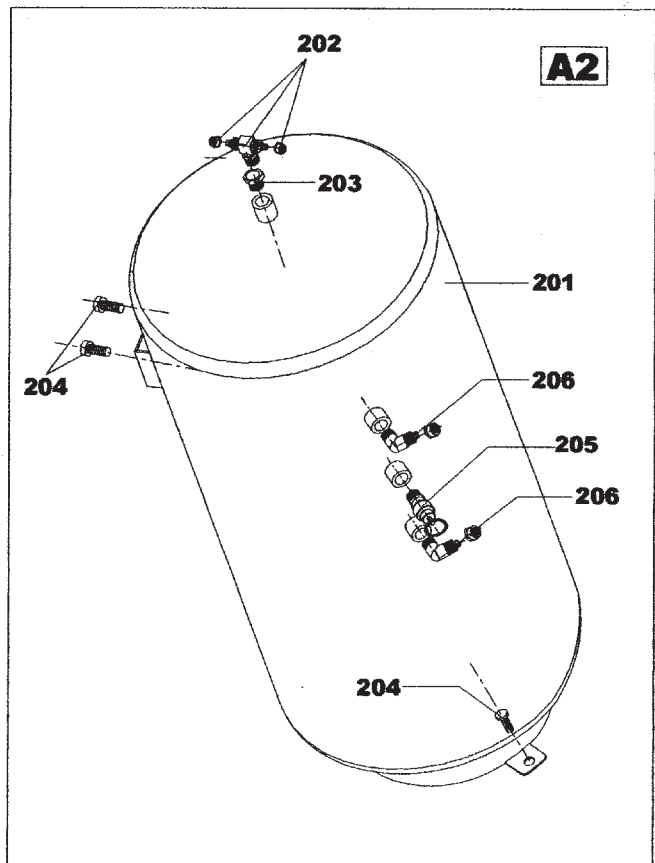
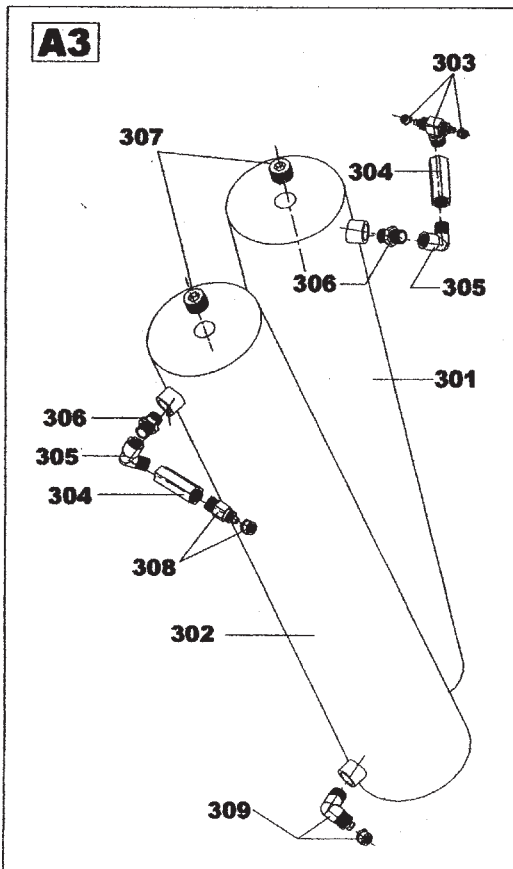
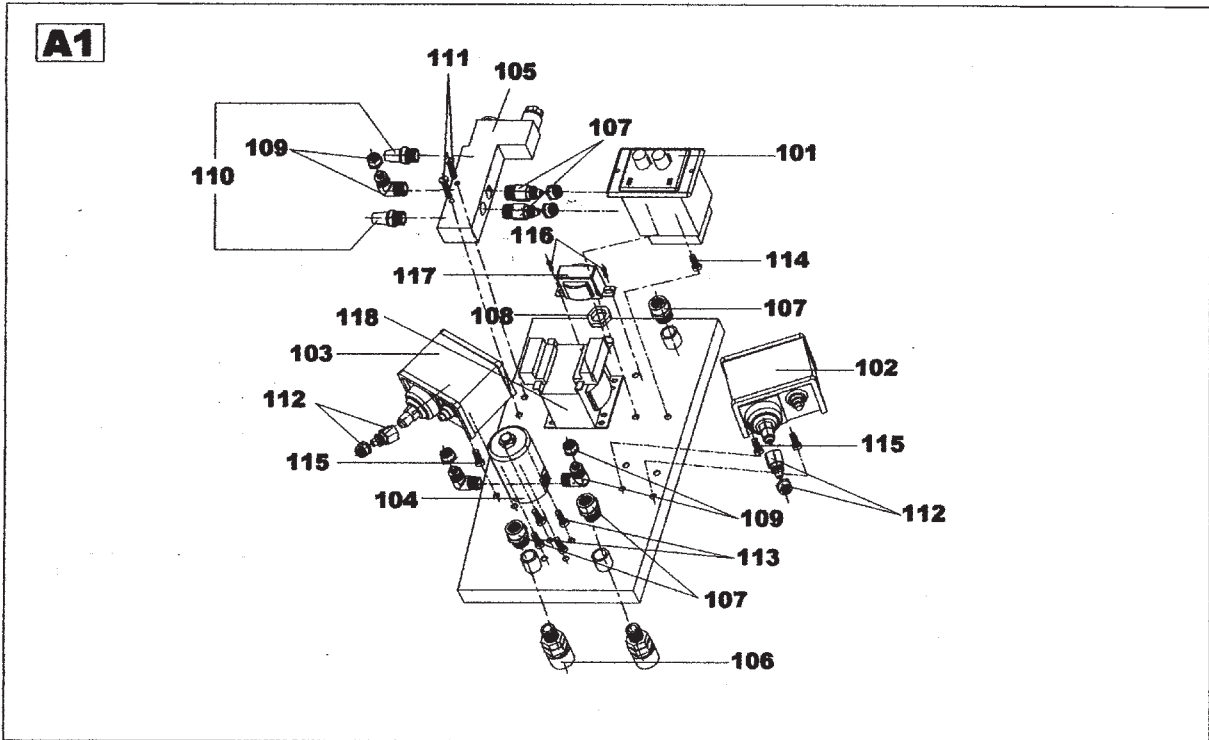

TIRE INFLATER UNIT ASSEMBLY DRAWING

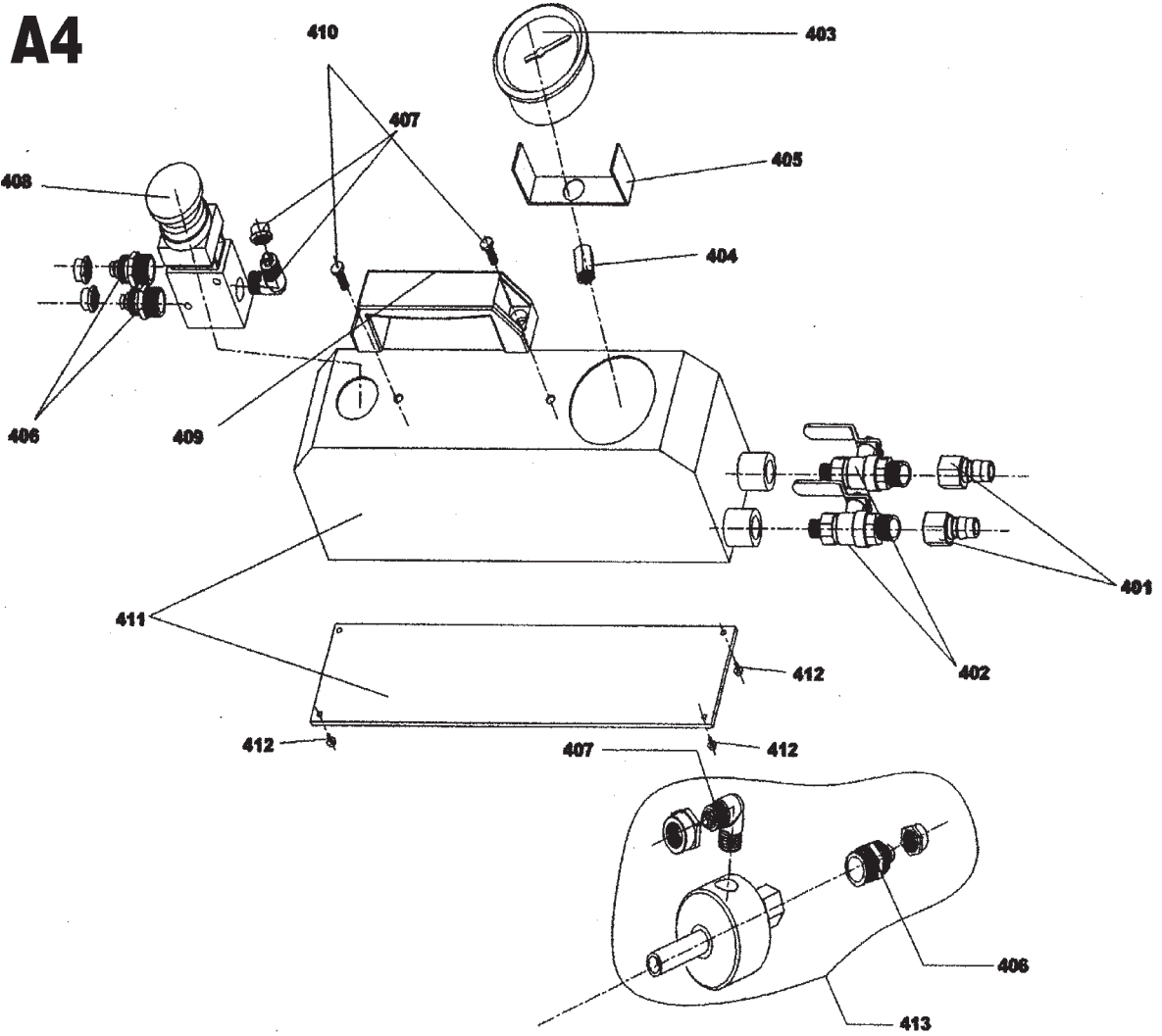

WARRANTY

CENTRAL MACHINERY®

LIMITED 90 DAY/1 YEAR WARRANTY

Harbor Freight Tools Co. makes every effort to assure that its products meet high quality and durability standards, and warrants to the original purchaser for a period of ninety days from date of purchase that the motor, the belts (if so equipped), and the blades (if so equipped) are free of defects in materials and workmanship. Harbor Freight Tools also warrants to the original purchaser, for a period of one year from date of purchase, that all other parts and components of the product are free from defects in materials and workmanship. This warranty does not apply to damage due directly or indirectly to misuse, abuse, negligence or accidents; repairs or alterations outside our facilities; or to lack of maintenance. We shall in no event be liable for death, injuries to persons or property, or for incidental, contingent, special or consequential damages arising from the use of our product. Some states do not allow the exclusion or limitation of incidental or consequential damages, so the above limitation of exclusion may not apply to you. **THIS WARRANTY IS EXPRESSLY IN LIEU OF ALL OTHER WARRANTIES, EXPRESS OR IMPLIED, INCLUDING THE WARRANTIES OF MERCHANTABILITY AND FITNESS.**

To take advantage of this warranty, the product or part must be returned to us with transportation charges prepaid. Proof of purchase date and an explanation of the complaint must accompany the merchandise. If our inspection verifies the defect, we will either repair or replace the product at our election or we may elect to refund the purchase price if we cannot readily and quickly provide you with a replacement. We will return repaired products at our expense, but if we determine there is no defect, or that the defect resulted from causes not within the scope of our warranty, then you must bear the cost of returning the product.

This warranty gives you specific legal rights and you may also have other rights which vary from state to state.

3491 Mission Oaks Blvd. • PO Box 6009 • Camarillo, CA 93011 • (800) 444-3353